

Wharfedale

COVER

PANTONE



PANTONE

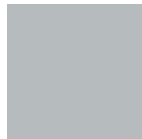

70th anniversary model

Wharfedale

Airedale Heritage

Airedale Heritage

CONTENTS

- User Warnings
- Quick Start Guide
- About Your Loudspeaker
- Servicing Your Loudspeaker
- Quality Assurance

WITHIN THIS PACK

- Certificate of Quality Assurance
- Systems and Driver Unit Test Reports
- Wharfedale History Book
- Gilbert Briggs Loudspeaker Book
- Single Wiring Links, 2 Types
- 4 x White Cotton Gloves

Wharfedale

Airedale Heritage

Wharfedale

USER WARNINGS

Please read the following notes carefully. They will help you to install your loudspeakers correctly and safely.

- Switch off the amplifier and all sources before making connections to your sound system. When you switch on the system or change sources, set the volume control to minimum and turn up the level gradually.
- The position of your Volume Control is NOT a reliable guide as to the maximum capabilities of your system. Playing the system with extreme settings of volume and tone controls may damage the amplifier and loudspeakers.
- Do not connect loudspeaker terminals to the mains supply.
- Ensure that your loudspeakers are correctly wired and are in phase.
- Do not subject your loudspeakers to excessive cold, heat or sunlight.
- **WARNING:** To reduce the risk of fire or electrical shock do not expose this product to rain or moisture. The product must not be exposed to dripping and splashing and no object filled with liquids – such as a vase of flowers – should be placed on the product.
- No naked flame sources – such as candles – must be placed on the product.
- Do not place heavy objects on top of loudspeaker cabinets. If you play them with the grilles removed be careful to protect the drive units from children and pets.
- Do not use makeshift stands. Always fit a manufacturer' approved stand using the instructions and the fixings provided. Your dealer will advise you.
- Do not attempt to dismantle the loudspeaker. There are no user serviceable parts inside and you will invalidate the warranty.
- Site your loudspeaker at least 0.5m away from TV sets and magnetic storage media.

Airedale Heritage

QUICK SETUP GUIDE (Airedale Heritage)

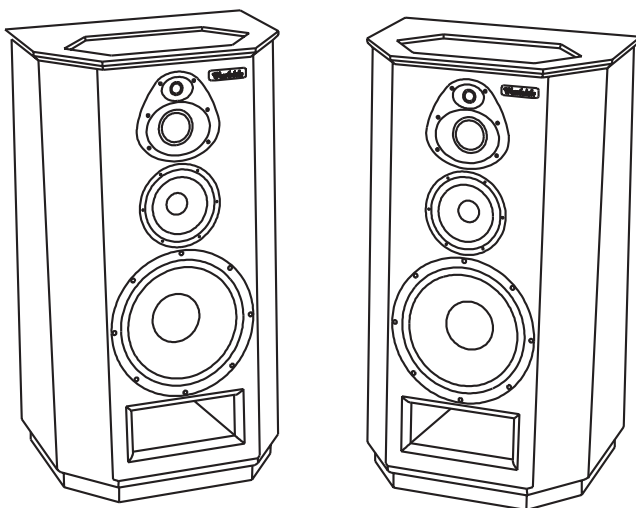

Wharfedale

Wharfedale

Airedale Heritage

Wharfedale

Setting Up the Airedale Heritage

- Safely unpacking
- Check you have
- Positioning the speakers
- Connection options
- Looking after your loudspeaker

Airedale Heritage

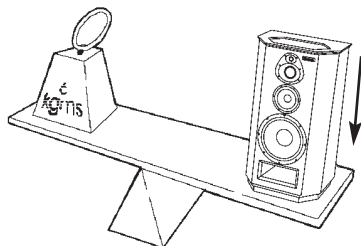

Your Airedale Heritage speakers are heavy. Take care when removing them from their packaging.

.....



Always take care when lifting heavy objects.
Lift the speakers out by their sides.

.....

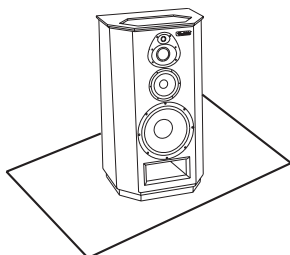

Lay the contents on a smooth surface to avoid accidental damage before installation.

.....

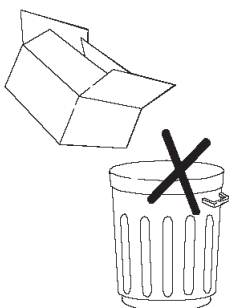

If possible, keep the packaging in case you need to move your speakers.

.....

SAFELY UNPACKING

Airedale Heritage

CHECK YOU HAVE

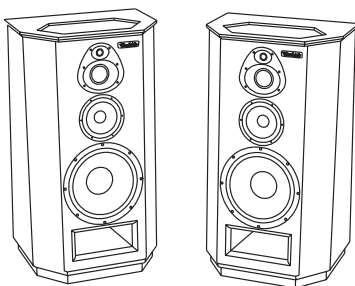

2 Speakers



User pack

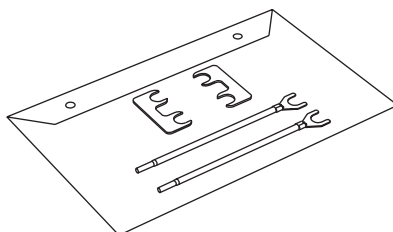

Accessories

Airedale Heritage

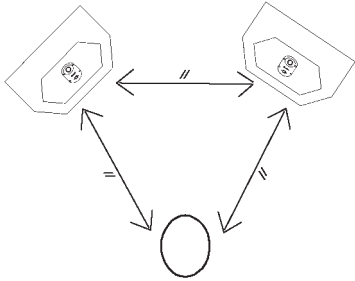

Positioning the speakers. Place the speakers so that you are the same distance from each. The distance between the speakers should be the same as between you and the speakers.

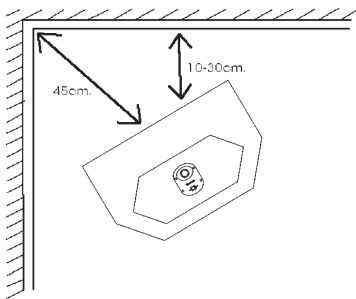

For best results the speakers should be 4 – 12 inches (10 – 30cm) in front of a wall and at least 18 inches (45cm) from any corner.

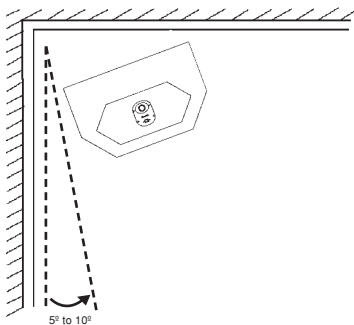

Angle speakers inward by 5° to 10° for a clearer, more tuneful mid range.

POSITIONING THE SPEAKERS

Airedale Heritage

CONNECTION OPTIONS

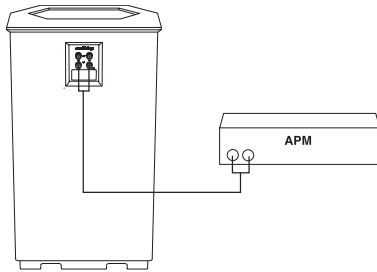

Single wired - a single cable from one amplifier drives each speaker. Note: These speakers are supplied in single wire configuration

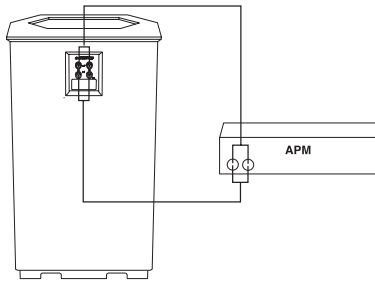

Bi- wired - a single amplifier, with separate wires to drive the bass/ mid unit and the treble unit.

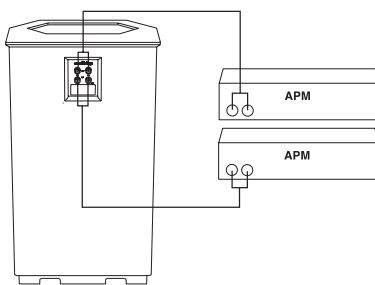

Bi- amplified - two amplifiers. One drives the bass/ mid unit. The other drives the treble unit.

Important Note, please make sure that heavy multi-standard cables are well connected and clamped. Single loose strands arcing can cause noise in the 15" woofer like a faulty speaker.

Airedale Heritage

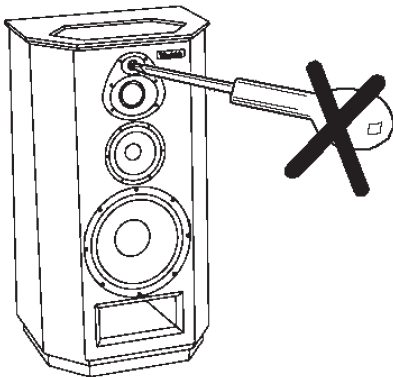

Do not open the speakers; there are no user serviceable parts inside.



Remove marks from the cabinet and polish it with a soft, slightly damp cloth.

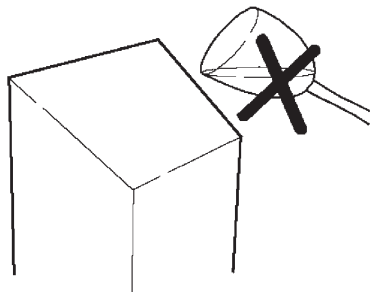

Avoid getting any liquid behind the grille.

To enable you to maintain the superb finish of your loudspeakers, the original matching walnut wax is available from your dealer.

LOOKING AFTER YOUR LOUDSPEAKER

Airedale Heritage

Wharfedale

TECHNICAL SUPPORT AND INFORMATION

For technical support, product queries and information please contact either your local retailer or the offices below.

UK

Wharfedale International Ltd.
IAG House, Sovereign Court,
Ermine Business Park,
Huntingdon. PE29 6XU
England
Tel : +44 (0) 1480 447700
Fax : +44 (0) 1480 431767
www.wharfedale.co.uk

USA

IAG America, Inc.
15 Walpole Park South,
Walpole,
MA 02081
USA
Tel: +1 (0) 508 8503950
Fax: +1 (0) 508 8503905
www.wharfedale.com

ASIA

Room 2310 - 2311 Press Building,
Shennan Road C,
Shenzhen,
China
Tel: 0086-755-82091200
Fax: 0086-755-82091205

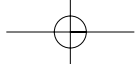

Airedale Heritage

ABOUT YOUR LOUDSPEAKER

Wharfedale

Wharfedale

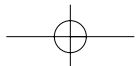
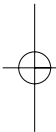
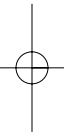

Airedale Heritage

‘THE AIREDALE HERITAGE’

The Airedale Heritage is the largest of the new series of speakers, it is a large format loudspeaker, utilising 5 drive units per speaker in a 4 way configuration.

The loudspeaker meets the demands of the highest level of hi-fi audiophile.

The audio range is covered by four ways so that no compromise is made in each section in the following areas;

- Very low distortion across the entire audio band.
- Low excursion requirement of the cone drivers.
- High flux magnet systems enabling good dynamic response and impulse control.
- Broadband dispersion for excellent stereo image and staging.
- General time coincident alignment of the drivers at the IEC listening position.
- Careful attention to all the component design, operation, integration and acoustics.

THE CABINET

Retro styled similar to the 1960's Wharfedale 'Airedale'. It is period furniture finished in classic oiled walnut real wood finish with antique gold/brown matching grille and trims. Solid walnut edging is used on the top and bottom edges, as well as the plinth, and the port and terminal panel edging.

The cabinet is a total internal volume of 178 litres, with a mid chamber of 14 litres. It is constructed entirely of 25mm MDF boards. The front baffle is tilted back to achieve the best average of acoustic centre to the IEC prime setup position, it is also angled back at the sides as the optimum for smooth edge refraction, per Olsen. It is additionally internally braced. A large transfer volume, low velocity port is utilised.

LOW FREQUENCY EXTENSION

The low frequency 380mm 15" driver has an F_s of 20Hz. The system F_b is 30Hz.

MIDRANGE COVERAGE

The bass to middle range is handled by a 200mm 8" driver, this is contained in a sealed chamber of 14 litres. The driver F_s is 50Hz and the system F_b is 80Hz.

The upper midrange is reproduced by a studio monitor quality 75mm 3" soft textile dome. The midrange is mounted in an aluminium fascia providing slight forward loading. Also in the same fascia plate is the 25mm soft dome tweeter.

HIGH FREQUENCY TWEETERS

The unit has a forward facing high output 25mm textile soft dome. An additional upward directed second tweeter may be selected via switch, to enhance the ambient effect of the highest frequencies.

Wharfedale

Airedale Heritage

COINCIDENT DRIVER ALIGNMENT

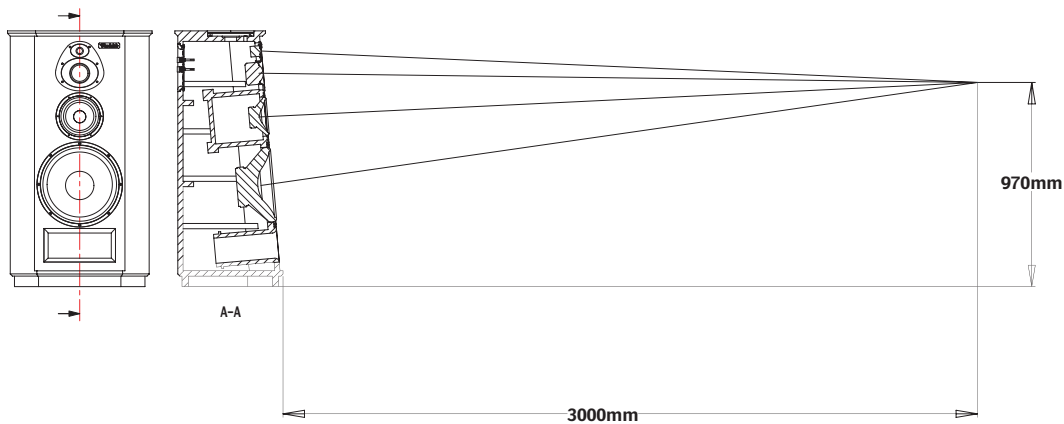

THE DRIVE UNITS

THE 380mm 15" BASS DRIVER

The bass driver incorporates a new design of cone, it is a sandwich cone combination of glass fibre/carbon fibre/glass fibre, it is very stiff and rigid. Energy losses in the cone transfer mechanism will be low. The cone edge is rim stiffened also.

Similarly, the lateral voice coil strength is very high being a combination of half hard aluminium and resin bonded to glass fibre. The dust cap/cover is of the same material as the cone. As the 15" operates only over the LF range it is only used over its pistonic range. The cone surround is a large half roll of synthetic butyl rubber, it has good inherent damping quality and has an integral trim ring. The chassis used and indeed on the 8" midrange also, is an open design, where narrow 'legs' and largest openings are used to minimise back reflections.

A dual spider configuration is used to extend the stable performance life of the driver and mechanical damping. A high performance traditional alnico magnet system is used. This features a flux stabilisation ring at the base of the yoke assembly. The magnet system is also fully vented throughout.

A real problem with high output bass systems is motional noise from the speakers particularly the bass driver. Careful assessment has eliminated pressure 'air noise' there are vents in the cone, in the spider, in the coil, in the magnet system, and in the chassis.

THE 200mm 8" UPPER BASS TO MID-RANGE DRIVER

The driver utilises a lightweight kevlar cone, a very rigid and responsive cone choice. A solid composition dust dome is used. The voice coil is wound on a vented aluminium former, and is also very rigid. The cone is terminated with a conventional half roll SBR surround with integral. A high performance alnico magnet is used. This also features a flux stabilisation ring at the base of the yoke assembly. The magnet system is also vented through.

Wharfedale

Airedale Heritage

THE 75mm 3" SOFT DOME MIDRANGE

A studio monitor quality large dome midrange is used over the crucial midband frequencies, 800Hz to 3.7kHz. A feature of this driver is very low distortion over its entire working range, it is typically less than 1% at 100dB at 1 metre.

It is mounted in a custom matched fascia plate to provide partial horn loading, giving a broad angle of dispersion to its upper crossover point. The fascia plate is of die cast aluminium, it is designed to place the units as close as possible for the best integration and point source effect. Both the units are loaded by elliptical horns to reduce the diffraction effects found with symmetrical openings. The edge of the fascia itself also has the same elliptical asymmetry. It has a large 75mm 3" voice coil again based on a rigid half hard aluminium former. The dome is pressure equalised by an underside baffle and chamber.

THE 25mm 1" SOFT DOME TWEETER

The highest frequencies are handled also by soft domes, these are a better choice than the metallic based domes that seem to add their own character to the treble. Again a feature of the tweeters as with the mids, is wide dispersion and very low distortion typically less than 1% at 100dB at 1 metre.

The forward unit features a high flux alnico magnet structure and is typically 93dB 1W@1M. This unit has a frequency response extending way over 20kHz to 45kHz.

The ambient effect of the highest frequencies can be enhanced by switching on the up firing tweeter, it is a complementary design to the front tweeter and forward sensitivity is not increased. It too is a 25mm soft dome but on a neodymium magnet system.

THE CROSSOVER AND WIRING

Monster Cable XP is used throughout the internal wiring. All inter-connections between wires and crossover/drivers are made by mechanical crimping. Soldering or iron parts are used within the crossover. No printed circuit boards are used. All inductors used are air cored and use large gauge wire for very low insertion loss. All capacitors used are either, low loss, low ECR polypropylene or high quality audio grade reversible electronics.

GENERAL

The reflex system uses a very large port. This has a large transfer volume and ensures low air speed within the port. Thiele - Small recommend 5-10% of the speed of sound and length approx to the diameter. The mach number for the Airedale Heritage port is M.N. 0.025. Very low. This is confirmed by the results, the Airedale Heritage port seeming virtually airless.

Wharfedale

Airedale Heritage

SPECIFICATIONS

Wharfedale

Wharfedale

Airedale Heritage

SYSTEM SPECIFICATIONS

Transducer Complement	4 way 5 drivers
Bass driver	15" 380mm alnico
Bass/Mid	8" 200mm alnico
Mid-range	3" 75mm soft dome
Tweeter	1" 25mm soft dome alnico
Super tweeter	1" 25mm soft dome
Nominal impedance	6 ohm
Impedance variation	4.0 - 17.0 ohms
Frequency response +/- 3dB	25Hz - 45kHz
Useable low frequency limit -3dB	25Hz - 45kHz
Low frequency limit -10dB	25Hz
Upper frequency limit -10dB	45kHz
SPL 1W@1m	90dB
Distortion 20 - 600Hz	>3% 100dB@1M
600 - 50kHz	>1% 100dB@1M
Power Handling	
Continuous weighted white noise	100 Watts
Peak	400 Watts
Max peak spl	114dB
Nominal coverage horizontal	90 degrees to 12 kHz
Nominal coverage vertical	30 degrees to 12 kHz
Enclosure type bass/mid	ported/sealed
Volumes bass/mid	178L/14L
System Fb	30Hz & 80Hz
Crossover frequencies	180Hz/700Hz/3.5Khz/9kHz
Construction material	entirely 25mm MDF
Finish	Hard Oiled & Waxed Walnut Veneer
Shape	5° angled trapezoidal
Component part numbers	
Bass driver	380mm 15" D.386
Bass/mid driver	200mm 8" D.401
Midrange speaker	75mm 3" D.389
Tweeter	25mm 1" D.390
Super tweeter	25mm 1" D.424
Product dimensions H x W x D	1215 x 688x 514
Net weight	80kg
Crate dimensions H x W x D	1482 x 818 x 630
Gross weight	110kg

Wharfedale

Airedale Heritage

380MM 15" SPECIFICATIONS

Frame material	Die cast aluminium
Cone & dome material	Glass/carbon/glass sandwich
Surround	Half roll sb rubber
Spiders	Dual spaced at 10mm
Coil size & type	51mm resin bond glass
Winding spec	2 layer round cu x 15mm
Magnet	120 dia x 90 dia x 60 alnico
Magnet weight	2232 grm
Gap flux density	1.2T
Top plate thickness	15mm
Piston range	Up to 300Hz
Venting	Cone, coil, pole, spiders, chassis and magnet cavity.
Thiele/small parameters	
Effective cone diameter	330mm
Re	5.7 ohm
Fs	20Hz
Qms	18.22
Qes	0.31
Qts	0.30
Mms	133 gm
Cms	0.48 mm/N
Vas	490L
BL	17.5 T/M

200MM 8" SPECIFICATIONS

Frame material	Die cast aluminium
Cone & dome material	Kevlar/paper
Surround	s b r single roll
Spider	single
Coil size & type	25mm aluminium
Winding spec	2 layer round cu x 10mm
Magnet D1 x D2 x H	86 dia x 62 x 44 alnico
Magnet weight	868 gm
Gap flux density	1.0 T
Top plate thickness	6mm
Optimum working range	80Hz - 250 Hz
Venting	Cone, coil, pole
Thiele/small parameters	
Effective cone diameter	165mm
Re	5.2 ohm
Fs	50Hz
Qms	8.31
Qes	1.01
Qts	0.90
Mms	19 gm
Cms	0.48 mm/N
Vas	31 L
BL	5.69 T/M

Wharfedale

Airedale Heritage

MIDRANGE SPECIFICATIONS

Part number	D.389
Dome material & size	75mm textile
Coil size & type	75mm aluminium
Magnet d1 x d2 x h	70 x 32 x 15
Magnet weight	248 gm
SPL 1w @ 1m	93dB
Fs	500Hz
Frequency range -3dB	400Hz - 5kHz
Distortion at 100dB @ 1m	typically <1%

TWEETER SPECIFICATIONS

FRONT TWEETER

Part number	D.390
Dome material & size	25mm textile
Coil size & type	25mm aluminium
Magnet d1 x d2 x h	50 x 37 x 30 alnico
Magnet weight	115 gm
SPL 1w @ 1m	92 dB
Fs	1kHz
Frequency range -3dB	800Hz - 40kHz
Upper frequency limit -10dB	45kHz
Distortion at 100dB @ 1m	typically <1%

TOP TWEETER

Part number	D.424
Dome material & size	25mm textile
Coil size & type	25mm aluminium
Magnet d x h	24 x 4 neodymium
Magnet weight	14 gm
SPL 1w @ 1m	92 dB
Fs	1kHz
Frequency range -3dB	800Hz - 40kHz
Upper frequency limit -10dB	45kHz
Distortion at 100dB @ 1m	typically <1%

CROSSOVER SPECIFICATIONS

Crossover sections	4 way
Type	Butterworth
Wiring	Monster cable XP
Connections	Mechanical Crimp
Crossover points at -6dB	
Bass	180Hz at 12dB/oct
Bass/mid low	180Hz at 12dB/oct
Bass/mid high	700Hz at 12dB/oct
Midrange low	7000Hz at 12dB/oct
Midrange high	3.5kHz at 12dB/oct
attenuation	-2dB
Tweeter	3.5kHz at 12dB/oct
attenuation	-1.3dB
Super tweeter	9kHz at 12dB/oct

Wharfedale

Airedale Heritage

SERVICING YOUR LOUDSPEAKER

Wharfedale

Wharfedale

Airedale Heritage

SERVICING

In the unlikely event that you may require to replace any part of your loudspeaker, you may contact your dealer and order all major parts as in the following drawing.

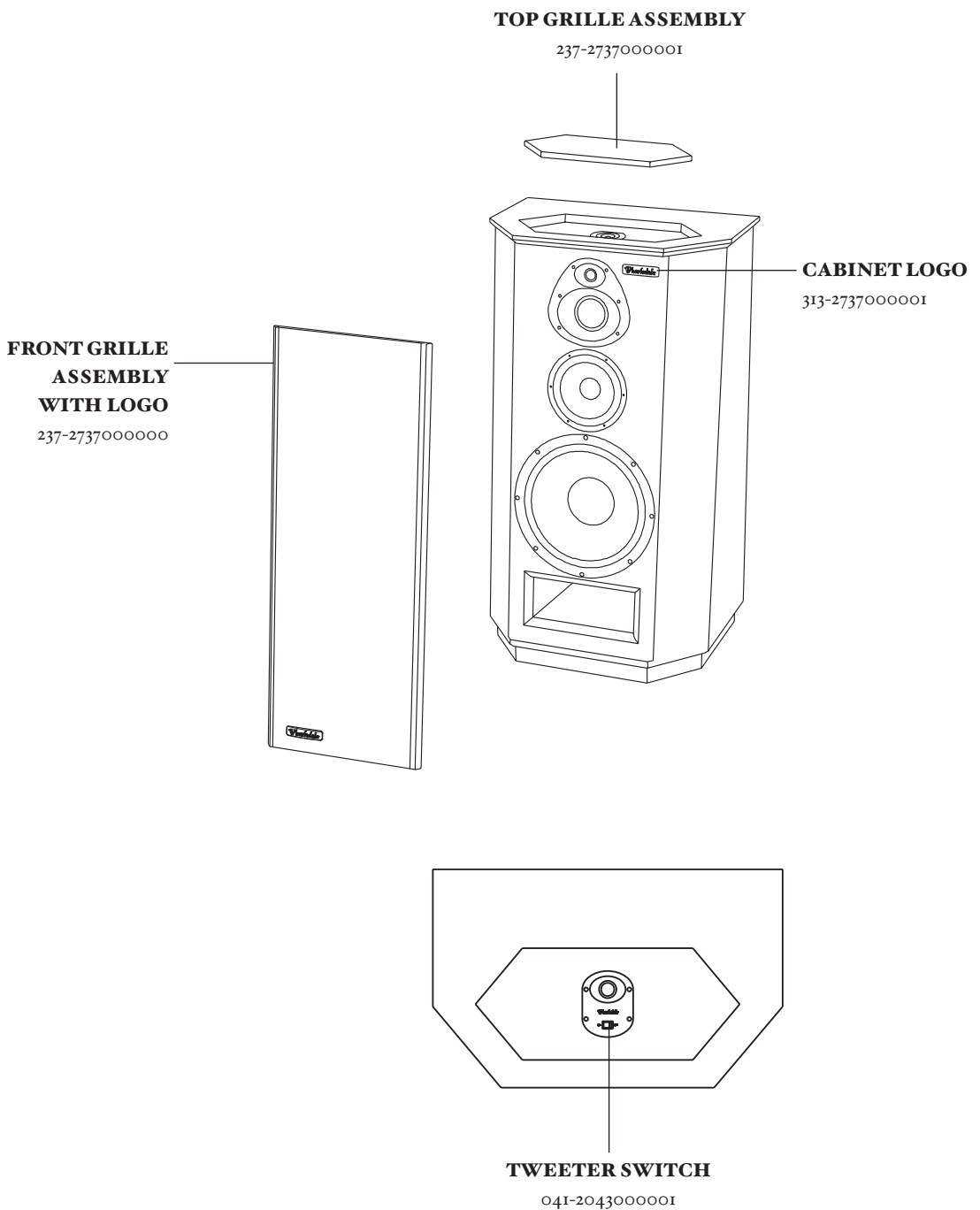

Wharfedale

Airedale Heritage

RED TERMINAL

046-000000011

BLACK TERMINAL

046-000000012

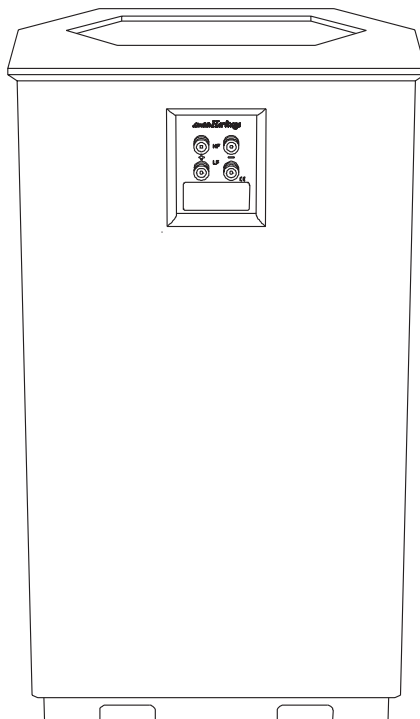
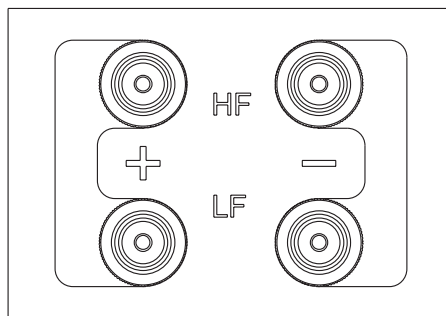

Wharfedale

Airedale Heritage

Wharfedale

TOP TWEETER

2D-14700-02



FRONT TWEETER

2D-39000-01



3" DOME MIDRANGE

2D-38900-01

Airedale Heritage

15" BASS UNIT

2D-38600-01



8" BASS/MID UNIT

2D-40100-01



Wharfedale

Airedale Heritage

Wharfedale

BASS CROSSOVER

600-2737000001

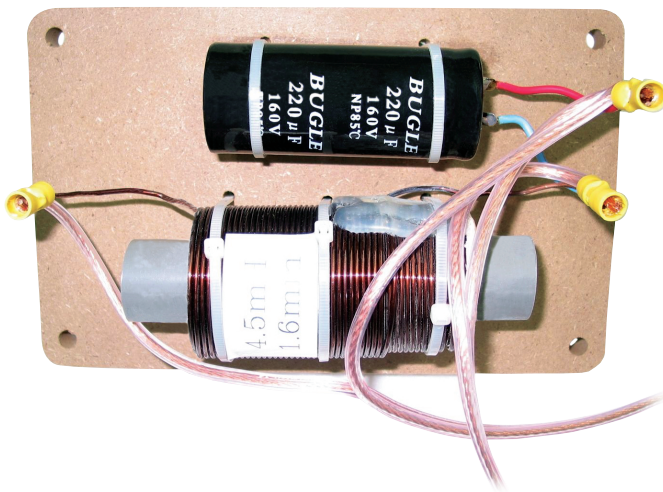

MAIN CROSSOVER

600-2737000002

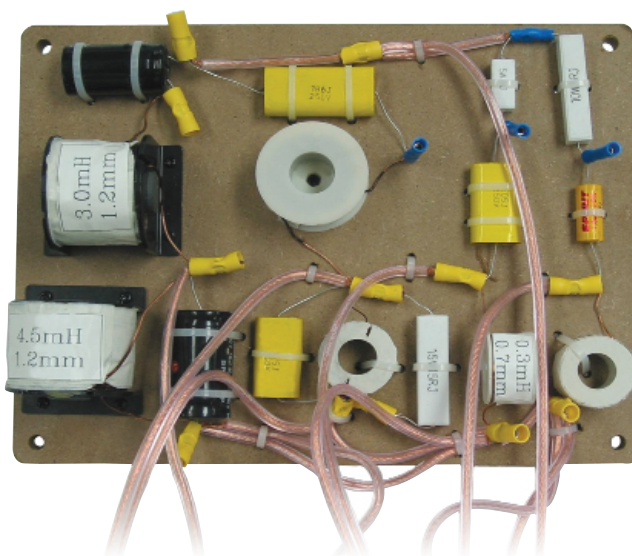

Airedale Heritage

CIRCUIT DIAGRAM

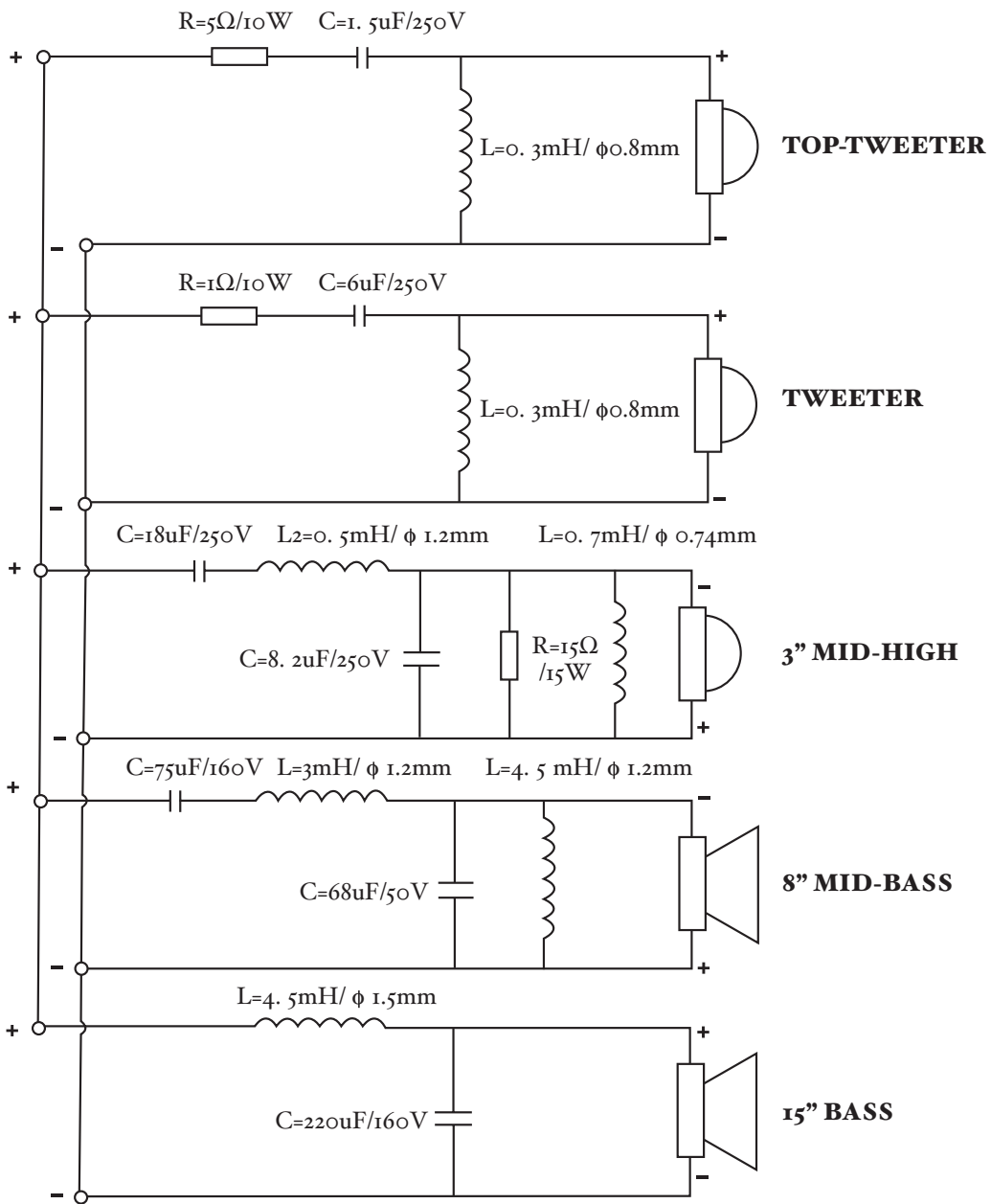

Wharfedale

Airedale Heritage

Wharfedale

QUALITY MANAGEMENT

Your Airedale Loudspeakers have been constructed to the highest standards of quality furniture finishes.

The acoustic components and the whole system have been manufactured to within very tight tolerances of +/- 1 decibel of sound pressure level.

All drive unit components are serially numbered and the original test record set for your loudspeakers is retained on file in our factory quality control department.

This enables us to give an extended guarantee of identical replacement parts should they ever be needed.

A copy of these test reports is included in the back of this manual. These should be retained for future reference.

A certificate of conformance to the original prototype specification, confirmed by the Airedale designer and engineering director is included in this pack.